

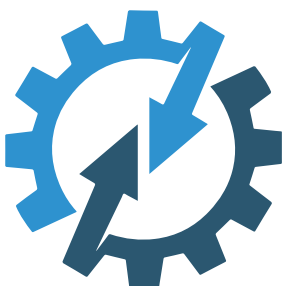

Vérin KCY



LSMotion

“La passion du monde de la Mécatronique”

VERINS ELECTRIQUE SÉRIE KCY

VERSION STANDARD

Existe en VERSION INOX

Tourillons sur
corps

Tourillons
arrière

Bride frontale

10 TAILLES
CAPACITÉ DE 10 A 250.000N

Tourillons sur
bride frontale

Option : Interchangeabilité
vérins pneumatique et
hydraulique

Option : Boîtier renvoi
Avec ou sans rotule et chappe

Option : fin de
courses intégrées

Option :
Lanterne compacte

DISPONIBLE EN DEUX VERSIONS**● Versions standard :**

- Piston en ACIER
- Corps de vérin en ALUMINIUM
- Palier d'extrémité en ALUMINIUM

● Versions INOX :

- Piston en INOX
- Corps de vérin en INOX
- Palier d'extrémité en INOX / AL

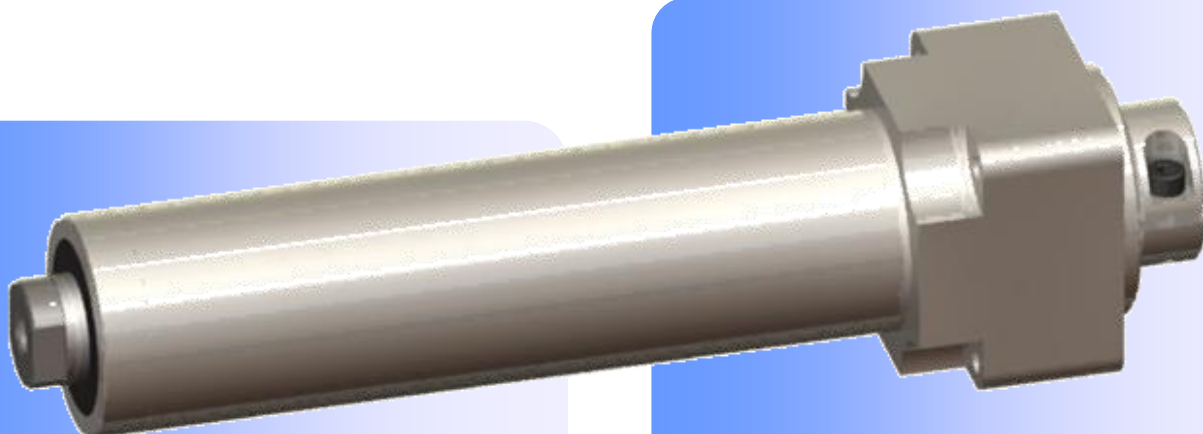
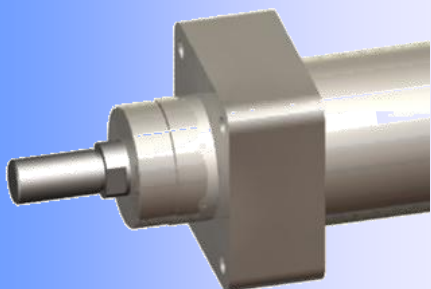
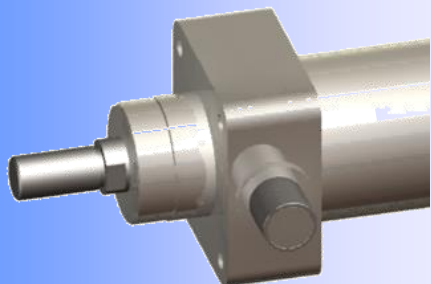
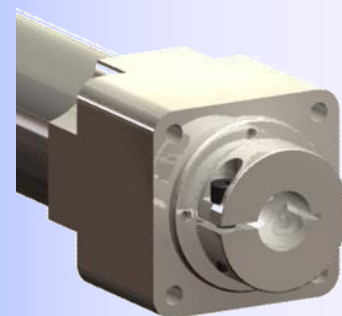
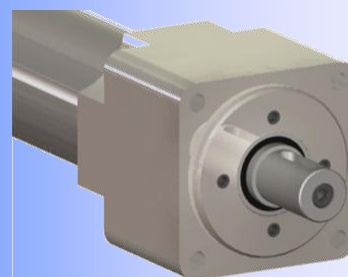
**BRIDE FRONTALE - OPTION
TYPE VERINS PNEUMATIQUES****BRIDE FRONTALE - OPTION
TYPE VERINS PNEUMATIQUES
AVEC TOURILLONS****LIAISON COMPACTE - STANDARD****Arbre creux pour
accouplement
moteur****SORTIE ARBRE MÂLE - OPTION**

KCY 32/8

Corps Ø32 - Vis Ø8

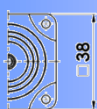
KCY 40/10

Corps Ø40 - Vis Ø10

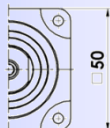
KCY 50/12

Corps Ø50 - Vis Ø12

KCY 60/16

Corps Ø60 - Vis Ø16

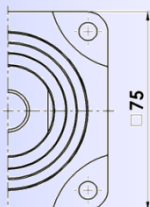
KCY 70/20

Corps Ø70 - Vis Ø20

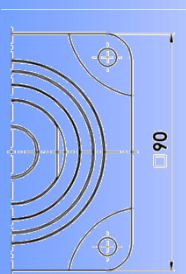
KCY 80/25

Corps Ø80 - Vis Ø25

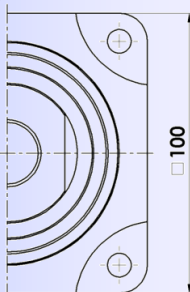
KCY 100/32

Corps Ø100 - Vis Ø32

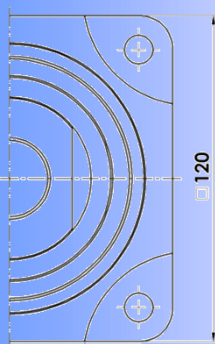
KCY 120/40

Corps Ø120 - Vis Ø40

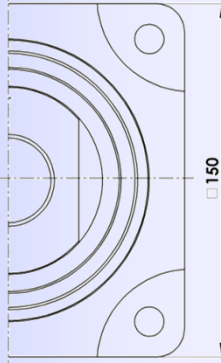
KCY 140/50

Corps Ø140 - Vis Ø50

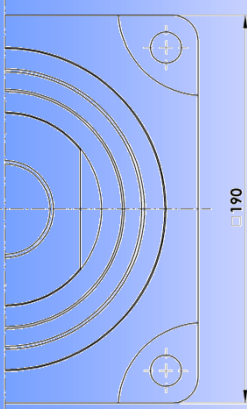
KCY 160/63

Corps Ø160 - Vis Ø63

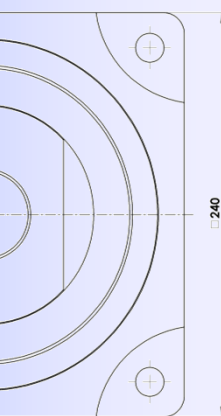
Dix tailles disponibles

KCY 32/8
 KCY 40/10
 KCY 50/12
 KCY 60/16
 KCY 70/20
 KCY 80/25
 KCY 100/32
 KCY 120/40
 KCY 140/50
 KCY 160/63

Principales caractéristiques :

- Version acier / aluminium
- Version inox

Options :

- Vis trapézoïdale
- Rainure de circlips / corps
- Anti-rotation
- Guidage renforcé

Accessoires :

- Lanterne
- Palier avant
- Rotule de piston
- Tourillons
- Synchronisation
- Renvoi d'angle
- Réducteur épicycloïdal

Motorisation et asservissement :

- Motorisation courant continu
- Motorisation Brushless
- Motorisation pas à pas
- Capteur de fin de course
- Capteur de prise d'origine machine (POM)
- Electronique de commande

KCY STANDARD

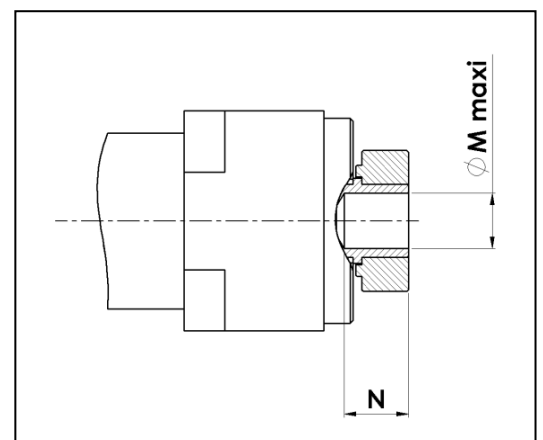
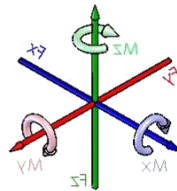
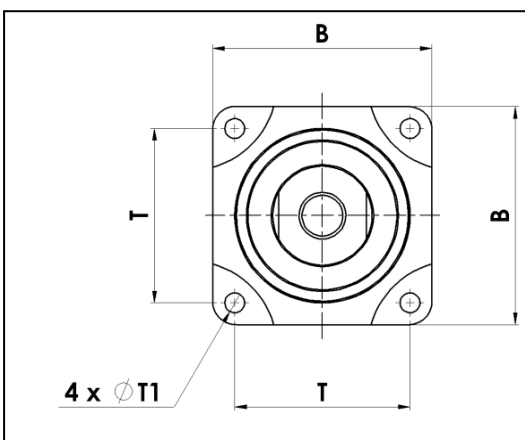
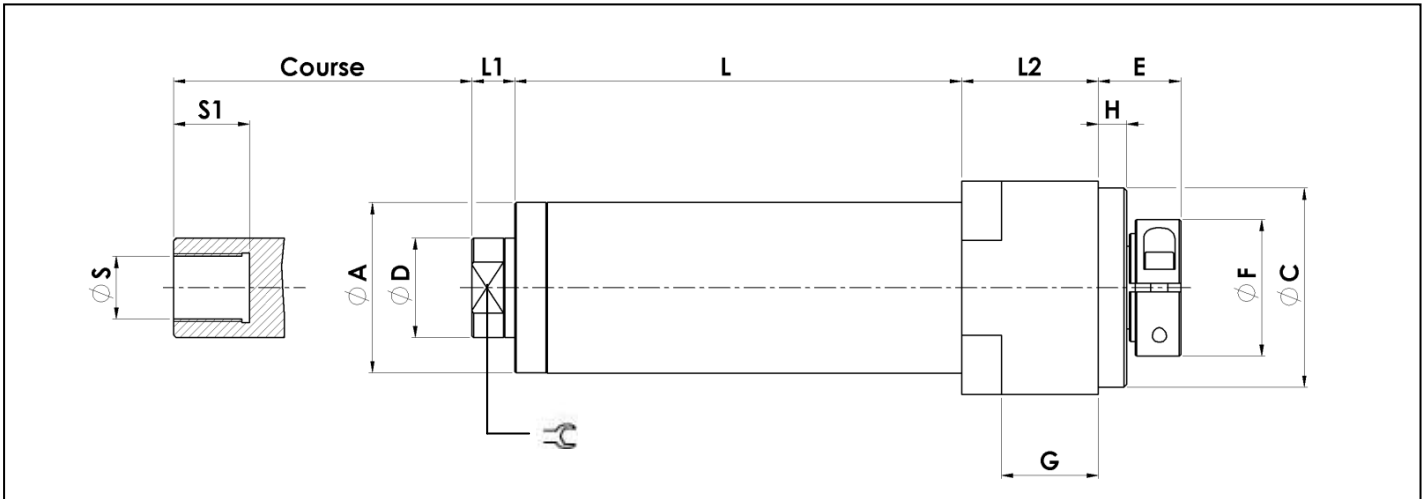

RÉFÉRENCES

	KCY	70	VB	2510	I	150	297	A _ _	A _ _	E200
Série										
Taille (ØC)										
VB : vis à billes ; VT : Vis TRAP RS : Vis à rouleaux satellite										
Ø x pas de la vis										
Version standard (S) ou inox (I)										
Course										
Longueur totale (L + L2 + course)										
Options (tourillons, prise d'origine, guidage renforcé, anti-rotation)										
Accessoires (A10 : lanterne)										
E200 (Exécution spéciale)										

DIMENSIONS (mm)

Séries	ØA	B	ØC	ØD	E	ØF	G	H	L + course
KCY 32-VB8	Ø32	46	Ø43	Ø16	19	Ø27	22	4	45
KCY 40-VB10	Ø40	50	Ø45	Ø20	20	Ø29	26	6	57
KCY 50-VB12	Ø50	65	Ø58	Ø25	22	Ø39	24	10	82
KCY 60-VB16	Ø60	75	Ø70	Ø35	29	Ø48	34	10	84
KCY 70-VB20	Ø70	90	Ø78	Ø40	37	Ø62	51	12	81
KCY 80-VB25	Ø80	100	Ø88	Ø50	44	Ø68	42	14	130
KCY 100-VB32	Ø100	120	Ø110	Ø60	49	Ø78	48	14	152
KCY 120-VB40	Ø120	150	Ø130	Ø70	57	Ø98	56	16	170
KCY 140-VB50	Ø140	170	Ø160	Ø80	66	Ø108	72	20	217
KCY 160-VB63	Ø160	190	Ø170	Ø100	86	Ø134	98	20	244

Séries	L1	L2	ØM (Maxi)	N	ØS	S1	T	ØT1	
KCY 32-VB8	10	32	Ø7	12	M8	10	36	Ø4,2	13
KCY 40-VB10	10	38	Ø8	14	M8	14	40	Ø4,2	17
KCY 50-VB12	12	36	Ø14	18	M12	20	52	Ø5,5	22
KCY 60-VB16	15	48	Ø19	22	M16	24	60	Ø6,8	30
KCY 70-VB20	18	66	Ø26	26	M20x1,5	28	72	Ø6,8	36
KCY 80-VB25	20	64	Ø32	30	M24x2	30	80	Ø8,5	41
KCY 100-VB32	22	74	Ø38	36	M30x2	32	95	Ø10,2	46
KCY 120-VB40	30	82	Ø45	38	M39x3	54	120	Ø12,5	60
KCY 140-VB50	30	98	Ø52	40	M45x3	61	140	Ø14	70
KCY 160-VB63	40	108	Ø60	50	M52x3	92	150	Ø17	90

CARACTÉRISTIQUES TECHNIQUES

Séries	VIS A BILLES (VB)			VIS TRAPEZOÏDALE (VT)	
	Ø x pas mm	Charge (N)*		Ø x pas	Charge (N)
		Fz dyn.	Fz stat.		Fz stat.
KCY 32-V__	8x2,5*	1500	2200	10x3	2100
KCY 40-V__	10x2 - 10x3 - 10x4*	1600	2600	12x3	2450
KCY 50-V__	12x2 - 12x4* - 12x5	3400	5400	16x4	4800
KCY 60-V__	16x5* - 16x20	5200	8700	20x4	7910
KCY 70-V__	20x5* - 20x20 - 20x50	11700	24400	24x5	22620
KCY 80-V__	25x5 - 25x10* - 25x25	20800	43900	28x5	41900
KCY 100-V__	32x5 - 32x10* - 32x20 - 32x40	28600	55400	36x6	52380
KCY 120-V__	40x5 - 40x10* - 40x20 - 40x40	63200	126800	40x6	90610
KCY 140-V__	50x10*	81700	188300	60x6	151320
KCY 160-V__	63x10*	91600	242400	70x10	198600

* : Réf / capacité

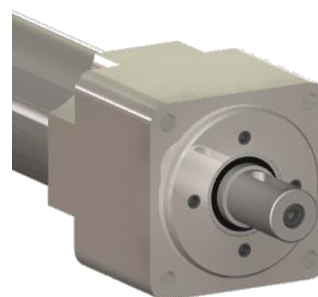
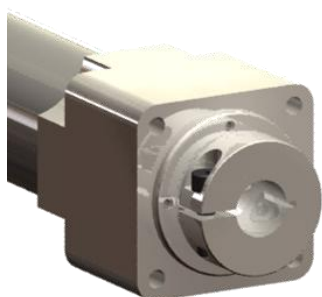
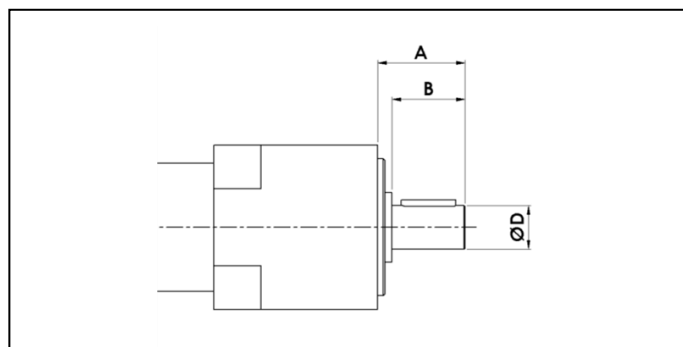
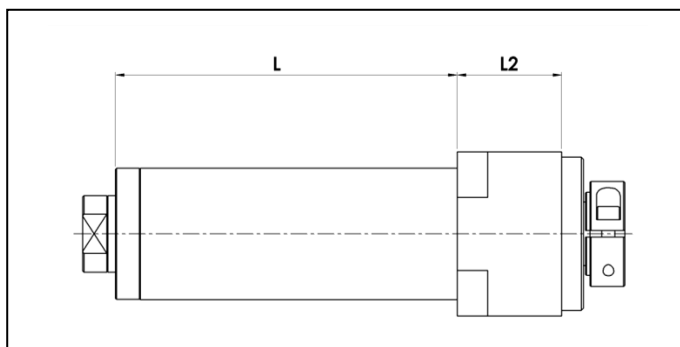
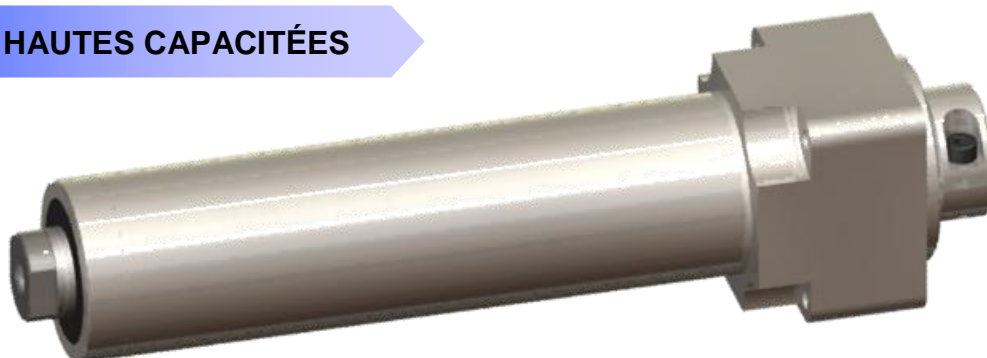
VIS A BILLES HAUTES CAPACITÉS

DIMENSIONS (mm)

Les dimensions non spécifiées sont identiques à la version standard

Séries	A	B	L + course	L2
KCY 150-HC40	68	54	395	118
KCY 200-HC50	76	60	435	128

CARACTÉRISTIQUES TECHNIQUES

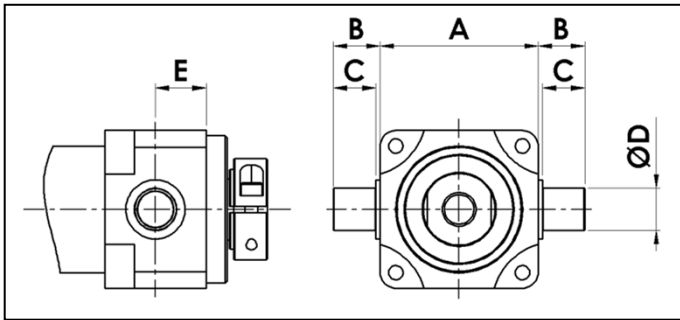
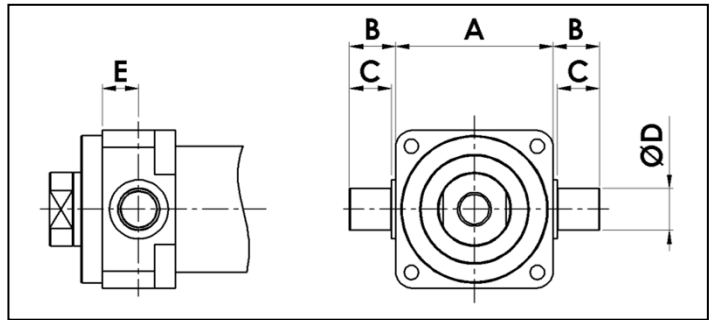
Séries	VIS A BILLES HAUTES CAPACITÉS (HC)		
	Ø x pas mm	Charge (KN)	
		Fz dyn. - C	Fz stat. - Co
KCY 150-HC40	40x12	180	382
KCY 200-HC50	50x16	320	635

TOURILLONS ARRIERE – KCY VB/VT

TOURILLONS SUR BRIDE FRONTALE

Séries	A	B	C	ØD	E
KCY 32-VB8	46	16	14	Ø14	16
KCY 40-VB10	50	18	16	Ø16	19
KCY 50-VB12	65	19	16,5	Ø18	18
KCY 60-VB16	75	22	20	Ø20	24
KCY 70-VB20	90	30	26	Ø25	28
KCY 80-VB25	100	32	30	Ø30	32
KCY 100-VB32	120	32	30	Ø35	37
KCY 120-VB40	150	38	40	Ø48	42
KCY 140-VB50	180	44	40	Ø50	46
KCY 160-VB63	200	50	46	Ø60	50

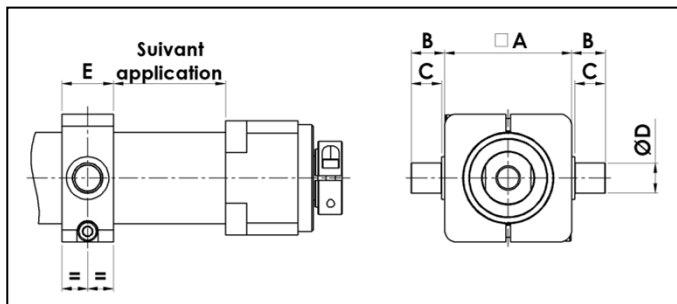
Séries	A	B	C	ØD	E
KCY 32-VB8	46	16	14	Ø14	11
KCY 40-VB10	50	18	16	Ø16	13
KCY 50-VB12	65	19	16,5	Ø18	14
KCY 60-VB16	75	22	20	Ø20	17
KCY 70-VB20	90	30	26	Ø25	20
KCY 80-VB25	100	32	30	Ø30	22
KCY 100-VB32	120	32	30	Ø35	25
KCY 120-VB40	150	38	35	Ø45	32
KCY 140-VB50	180	44	40	Ø50	35
KCY 160-VB63	200	50	45	Ø60	40

TOURILLONS SUR CORPS – KCY VB/VT

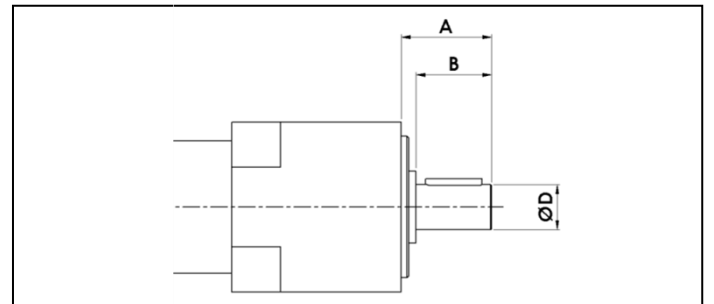
Séries	A	B	C	ØD	E
KCY 32-VB8	46	16	14	Ø14	19
KCY 40-VB10	58	18	16	Ø16	24
KCY 50-VB12	69	19	16,5	Ø18	29
KCY 60-VB16	84	22	20	Ø20	34
KCY 70-VB20	94	30	26	Ø25	39
KCY 80-VB25	104	32	30	Ø30	44
KCY 100-VB32	129	32	30	Ø35	48
KCY 120-VB40	132	38	35	Ø45	58
KCY 140-VB50	178	44	40	Ø50	68
KCY 160-VB63	220	50	45	Ø60	78

ARBRE MÂLE – KCY VB/VT - KCY / PCA

Séries	A	B	ØD
KCY 32-VB8	26	20	Ø10
KCY 40-VB10	34	26	Ø14
KCY 50-VB12	44	32	Ø17
KCY 60-VB16	49	36	Ø19
KCY 70-VB20	57	42	Ø22
KCY 80-VB25	64	46	Ø24
KCY 100-VB32	70	52	Ø30
KCY 120-VB40	76	56	Ø35
KCY 140-VB50	87	62	Ø40
KCY 160-VB63	91	66	Ø45

DÉTECTEURS

Réf. A70

Les capteurs sont fixés sur le corps du vérin. La détection s'effectue au moyen d'un aimant qui se déplace avec le piston. Trois capteurs peuvent être placés par vérin et sont réglable en position.

● **Référence :**

A76 : Détecteur magnétique normalement ouvert

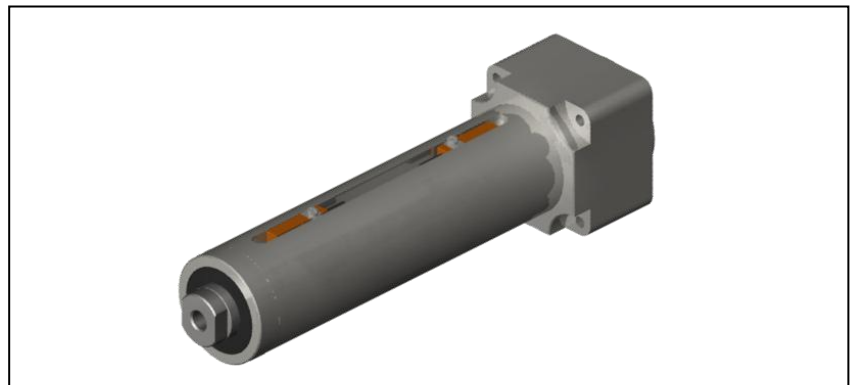

BOÎTIER RENVOI MOTEUR

Réf. A20

Les vérins KCY peuvent être équipés de boîtier renvoi moteur.

Option :

- chappe sur boîtier.
- Chappe sur piston
- Rotule sur piston

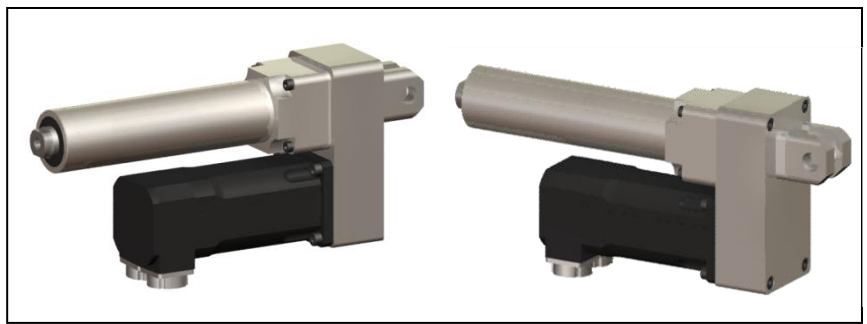

LANTERNE COMPACTE

Réf. A10C

Les lanternes compactes permettent le montage d'un réducteur ou d'un moteur sur l'unité KCY.

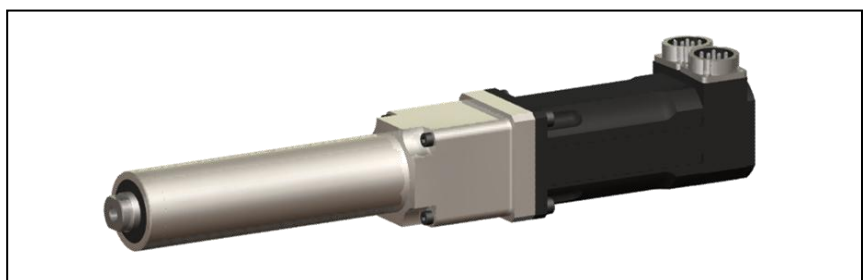

BRIDE FRONTALE

Réf. BF

La bride frontale permet d'obtenir une fixation de type vérins pneumatique.

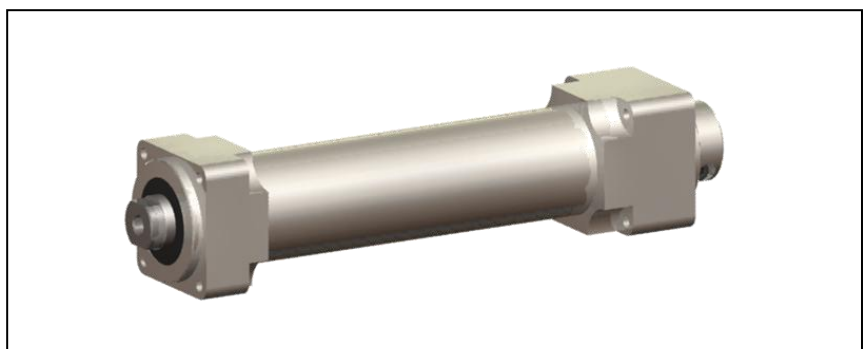

SORTIE PISTON SUR ARBRE CANNELÉ - Réf. KCY / PC _ / _ (ex. KCY / PC 60/12 A70)

- Guidage et anti-rotation par douilles à billes sur arbre cannelé
- Ensemble précis, indéréglable, durée de vie importante
- Grande précision de guidage et de positionnement angulaire
- Double guidage interne pour couple de basculement élevé

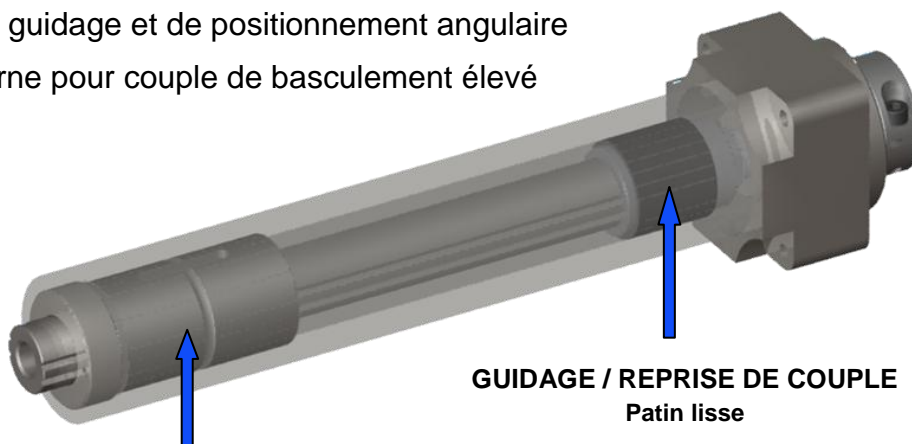
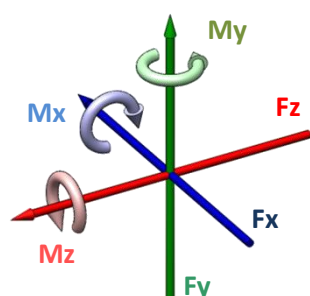

GUIDAGE et ANTI-ROTATION
Arbre cannelé sur douille à billes

GUIDAGE / REPRISE DE COUPLE
Patin lisse

DIMENSIONS

Les dimensions non spécifiées sont identiques à la version standard KCY

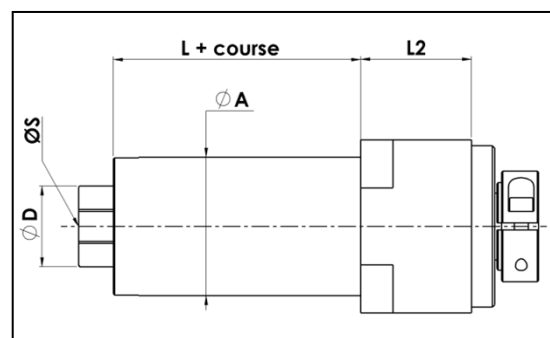
Séries	ØA	L + course	L2	ØD	ØS*
KCY/PC 60/12 A70	Ø70	200	48	23	M20x1,5
KCY/PC 70/16 A80	Ø80	224	66	28	M24x2
KCY/PC 80/25 A90	Ø90	280	64	37,4	M30x2
KCY/PC 100/32 A110	Ø110	290	64	47	M36x3

CARACTÉRISTIQUES TECHNIQUES

Séries	Vis à billes	Couple Mz (N/m)		Charge radiale Nez piston Fx / Fy (KN)	
		dyn.	stat.	dyn.	stat.
KCY/PC 60/12 A70	Ø12	289	412	18,6	23,2
KCY/PC 70/16 A80	Ø16	637	882	30,8	37,5
KCY/PC 80/25 A90	Ø25	674	934	43,3	68
KCY/PC 100/32 A110	Ø32	1390	3180	49	81

SOLUTION KVER**● VERSION STANDARD**

Roulement complémentaire
pour reprise de couple /
effort radial

Corps en aluminium extrudé, anodisé

Anti-rotation interne

Centrage et trous de
fixation

Guidage renforcé

Fixation
tourillons

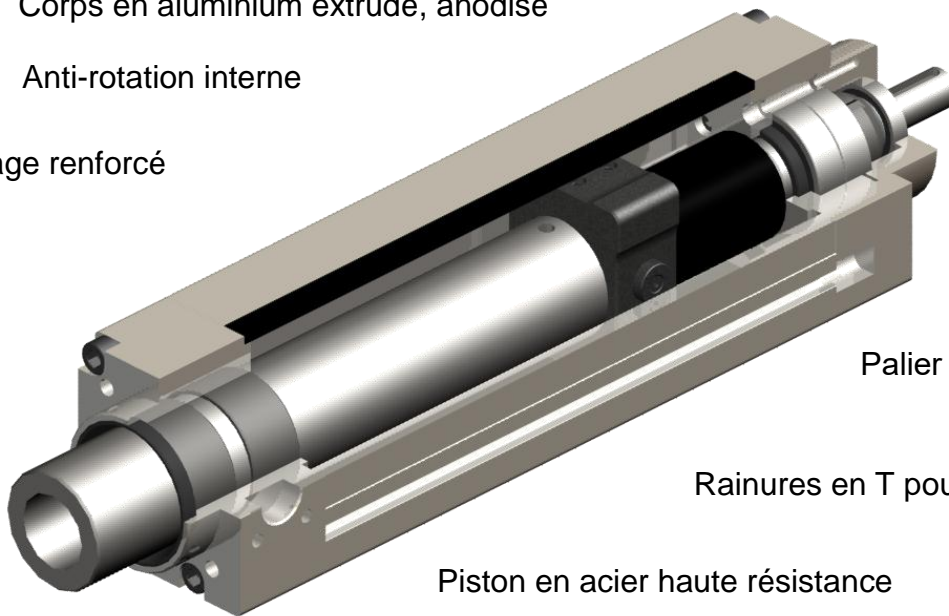

Palier d'extrémité fortement
dimensionné

Rainures en T pour fixation

Piston en acier haute résistance





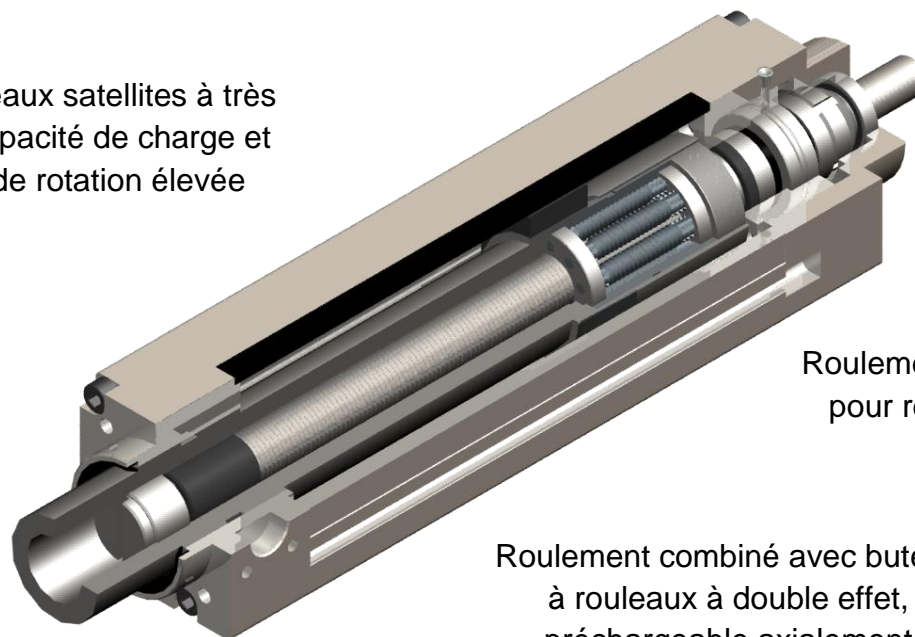













● OPTION : PALIER RENFORCÉ ET VIS A ROULEAUX SATELLITES

Vis à rouleaux satellites à très
grande capacité de charge et
vitesse de rotation élevée



Roulement complémentaire
pour reprise de couple /
effort radial

Roulement combiné avec butées
à rouleaux à double effet,
préchargeable axialement

		LITL C - PB		LITL CR		NOVAXE		CREAXE-C		DUACO		LITL V		MVIS		DUAVI		LIGAL		GALAXE		ROLEX		LIGAL - C		CREGAL-C		CREAXE-V		CREGAL-V		ROLVIS		LIGAL - V																			
		SIMPLE	SIMPLE	SIMPLE	SIMPLE	DOUBLE	SIMPLE	DOUBLE	SIMPLE	SIMPLE	SIMPLE	DOUBLE	SIMPLE	SIMPLE	SIMPLE	DOUBLE	SIMPLE	SIMPLE	SIMPLE	SIMPLE	SIMPLE	SIMPLE	SIMPLE	SIMPLE	SIMPLE	SIMPLE	SIMPLE	SIMPLE	SIMPLE	SIMPLE	SIMPLE	SIMPLE	SIMPLE	SIMPLE																			
Type de Module		COURROIE																		SANS				COURROIE				VERIN				VIS																					
ENTRAINEMENT		COURROIE																		SANS				COURROIE				VERIN				VIS																					
Profile Longueur x Hauteur	62 x 36	62 x 34	55 x 55	62 x 62	80 x 40	62 x 36	80 x 40	62 x 62	80 x 80	100 x 50	55 x 55	80 x 40	62 x 36	80 x 40	62 x 62	80 x 80	100 x 50	55 x 55	80 x 40	62 x 34	62 x 50	62 x 62	80 x 80	62 x 62	80 x 80	100 x 50	62 x 50	62 x 62	80 x 80	100 x 50	62 x 62	80 x 80	100 x 50	62 x 34	62 x 50	62 x 62	80 x 80	100 x 50															
	90 x 55	90 x 48	80 x 80	115 x 105	125 x 85	90 x 55	125 x 85	90 x 80	115 x 105	150 x 80	125 x 85	90 x 80	115 x 60	125 x 85	90 x 72	90 x 90	125 x 85	105 x 105	90 x 90	90 x 48	90 x 72	90 x 90	115 x 85	90 x 72	90 x 90	115 x 85	90 x 72	90 x 90	115 x 85	125 x 85	115 x 85	90 x 48	90 x 72	90 x 90	115 x 85	115 x 85	90 x 48	90 x 72	90 x 90	115 x 85	115 x 85												
GUIDAGE	X	X	X	X	X	X	X	X	X	X	X	X	X	X	X	X	X	X	X	X	X	X	X	X	X	X	X	X	X	X	X	X	X	X	X	X	X	X	X	X	X	X											
CHARGE	0 à 50 kgs	X	X	X	X	X	X	X	X	X	X	X	X	X	X	X	X	X	X	X	X	X	X	X	X	X	X	X	X	X	X	X	X	X	X	X	X	X	X	X	X	X	X	X	X								
	> 50 kgs	O	O	X	X	O	X	X	X	X	X	O	O	X	X	X	X	X	X	O	X	X	O	O	O	O	O	O	O	O	O	O	O	O	O	O	O	O	O	O	O	O	O	O	O	O	O						
	<= 1,5 m/s																																																				
VITESSE	> 1,5 m/s	X	X	X	X	X	X	X	X	X	X	X	X	X	X	X	X	X	X	X	X	X	X	X	X	X	X	X	X	X	X	X	X	X	X	X	X	X	X	X	X	X	X	X	X	X	X						
	<= 0,15 mm	X	X	X	X	X	X	X	X	X	X	X	X	X	X	X	X	X	X	X	X	X	X	X	X	X	X	X	X	X	X	X	X	X	X	X	X	X	X	X	X	X	X	X	X	X	X	X					
PRECISION	> 0,15 mm	X	X	X	X	X	X	X	X	X	X	X	X	X	X	X	X	X	X	X	X	X	X	X	X	X	X	X	X	X	X	X	X	X	X	X	X	X	X	X	X	X	X	X	X	X	X	X	X				
VUE "3D" DES MODULES																																																					
		MODULE STANDARD																		MODULE STANDARD				MODULE STANDARD				MODULE STANDARD				MODULE STANDARD				MODULE STANDARD				MODULE STANDARD				MODULE STANDARD				MODULE STANDARD					
VUE "3D" DES MODULES																																																					
		MODULE STANDARD																		MODULE STANDARD				MODULE STANDARD				MODULE STANDARD				MODULE STANDARD				MODULE STANDARD				MODULE STANDARD				MODULE STANDARD				MODULE STANDARD				MODULE STANDARD	

SUR DEMANDE

MODULE STANDARD

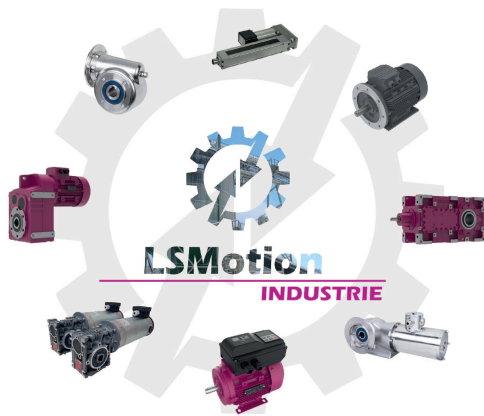

INDUSTRIE

- Réducteur
- Moteur Asynchrone
- Moteur Courant continu
- Motoréducteur
- Vérin électrique
- Module linéaire
- Indexeur
- Variateur
- Cobot



AGRICOLE

- Boitier renvoi d'angle
- Réducteur mélangeuse
- Transmission épandeur
- Multiplicateur

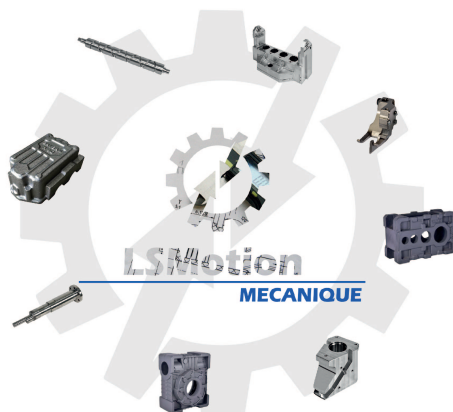

MECANIQUE

- Usinage
- Mécano-soudure
- Chaudronnerie fine
- Fonderie



MOBILE

- Réducteur de roue électrique
- Boitier différentiel
- Moteur flux axial
- Roue électrique
- Pont

LSMotion
3 bis avenue du stade
77400 Lagny sur marne
09.72.19.92.57 www.lsmotion.fr